



INNOVATIVE DECKING SOLUTIONS

WORKING WITH METAL FOR OVER 130 YEARS

Introduction To Synergised™ Aluminium Deck System

Synergised™ Decking System for Balconies and Terraces

Fully non-combustible fire rated A1 and A2fl-s1 aluminium decking system designed for both residential and commercial environments such as high-rise balconies, walkways, roof terraces, pubs, gardens and all other high-rise applications and public areas.

Available in 3 contemporary colours our deck boards are manufactured from structural grade 6063 T6 aluminium with 100 micron Qualicoat™ premium powder coating, making it the ideal decking solution for high footfall areas. The premium coating is low slip and provides low surface temperatures underfoot.



Installation couldn't be easier, with our innovative adjustable cradle base and joist support system that offers up to 50% cost saving compared to other solutions.

Once installed the system is long lasting and low maintenance with a manufacturer's limited warranty of 10 years on the coating with an expected product life expectancy +25 years.

- ◆ Euroclass Classifications A1 and A2fl-s1 fire rated
- ◆ Made from structural grade 6063 T6 aluminium
- ◆ Ideal for high rise concrete balconies & terraces
- ◆ Up to 50% cost saving compared to other systems
- ◆ 100 micron Qualicoat™ premium powder coating
- ◆ Adjustable cradle and deck support system
- ◆ Cradle spacing up to 1800mm
- ◆ Low surface temperatures
- ◆ Long lasting and low maintenance
- ◆ Lightweight and easy to install
- ◆ Mill finish subframes and cradles
- ◆ 10 year warranty on powder coating

Why choose Synergised?

When choosing a new or replacement deck, there will be several factors that influence your decision particularly the application and whether you require fire rated performance. Synergised is an innovative new aluminium deck system where the deck boards, subframe and adjustable cradles have been designed to replace non-fire rated products to provide peace of mind. The system offers unsurpassed durability and longevity, using 6063 T6 aluminium, 100 micron Qualicoat™ premium powder coating and mill finish.

Fire Rating

Synergised meets the requirements for any application that requires a Euroclass Classifications A1 and A2fl-s1 fire rating, such as residential and mixed-use developments above 4 storeys, plus schools, universities, hospitals & libraries and care homes. New or replacement decks on balconies that are above 11m in height.





| | |
|---|-----------|
| Before you start - Think safety first | 04 |
| Consider the environment | 05 |
| Before you start - Get the right tools | 06 |
| Components and their use - Decking system | 07 |
| Components and their use - Fixings | 08 |
| Understanding your requirements | 09 |
| Option 1 - Solid base | 10 |
| Option 2 - Fresh ground, no solid base | 12 |
| Option 3 - Existing substructure | 13 |
| Adjustable cradle installation | 14 |
| Joist installation | 15 |
| Starter clips installation | 16 |
| Decking board Installation | 17 |
| Deck joining plate installation | 18 |
| Cutting a board | 19 |
| Starter clip installation - final board | 20 |
| End cap installation | 21 |

Before you start - Think safety first



Cutting, drilling and handling aluminium sections can be hazardous, please ensure that you wear the correct personal protective equipment (PPE), and ensure that anyone in the work area is aware of the risks. Children must not be allowed in or near the work area.

The following items are mandatory



Drilling and cutting aluminium results in hot swarf which can easily lead to extensive eye damage and even permanent loss of vision, always wear a face shield or goggles when cutting and drilling.



Drilling and cutting aluminium causes a significant noise which can easily lead to extensive hearing damage, always wear suitable hearing protection when cutting and drilling.



Drilling and cutting aluminium causes dust which can cause damage to the respiratory system, always wear a suitable mask when cutting and drilling.

The following items are recommended, however these and others may be mandatory on some sites. Please check with the site foreman before starting any work.



Some of the sections may weigh in excess of 20kg, and some edges may be sharp. It is recommended that suitable safety boots are worn to protect your feet



Drilling and cutting aluminium may result in sharp edges, it is recommended that gloves are worn at all times



Hard hats are recommended in all instances where you may bump your head or there is a risk from falling objects

Consider the Environment



Please consider the environment when installing your new decking, a small amount of effort can have a big impact.



Our decking products are produced from readily recyclable materials, please recycle any off-cuts properly rather than throwing them in with regular waste. Most scrap metal merchants will accept off-cuts free of charge.



The cardboard and paper waste we use for packaging our fixings and decking boards is also readily recyclable, please ensure this is also recycled correctly.



We work really hard to keep the non-recyclable content of our packaging to an absolute minimum, please ensure that this and any swarf are put in the bin to minimize the impact on nature and your local environment.

Before you start - Get the right tools



Hammer -
(16oz / 0.5 kg).



PZ2 - Pozi drive screw driver (must be 5mm or less shaft diameter).
X15 - Torx driver (Decking end caps).
X40 - Torx driver (Base structure), consider using a Torx Allen key as an alternative.



Rubber mallet -
(12 - 16oz / 0.4 - 0.5kg).



Spanner -
13mm.



Sealant gun and coloured sealant to match decking colour.



Measuring tape -
Minimum 5m length.



A couple of **Clamps** (G - clamp or other) with 60mm throat.



Electric jigsaw - with 10 - 12 TPI blade (suitable for cutting aluminium) up to 3mm thick.



Level.



Electric compound mitre saw - with blade suitable for cutting aluminium, 80 - 100 teeth on a 305mm diameter is the minimum requirement. The blade must be suitable for fine cutting of aluminium. A bench saw or circular saw is not suitable.



Electric drill - with 8.5mm HHS diameter drill bit (suitable for metal). A 3.5 mm drill bit will also be required for pilot holes in 20 and 70 mm joists if the corner plate is used.

Components and their use - Decking system



20mm joist (Code: **79J020**), used where very low profile subframe is required.

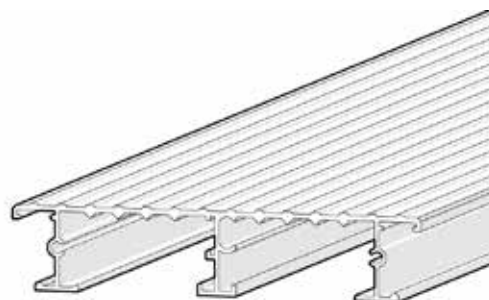

30mm high load decking board (Code: **79DB30A**, **79DB30B** & **79DB30SS**).

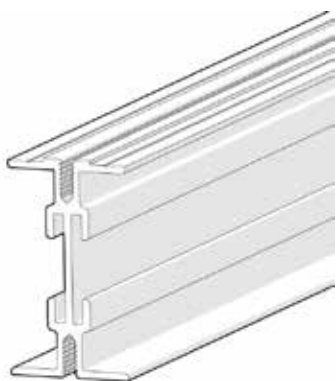

70mm joist (Code: **79J070**), used in applications where medium loads or a low build up is required.



Post section, used for anchoring decking into the ground. Post section should be between 80mm + 100mm with a minimum wall thickness of 3mm if using aluminium or 2mm if using galvanised mild steel.

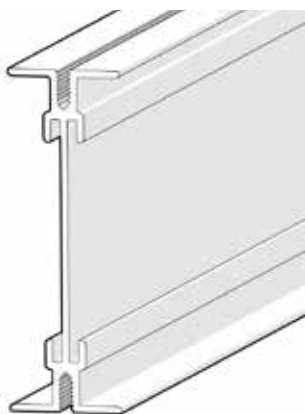

120mm joist (Code: **79J120**), used where high loads or greater spans are required.

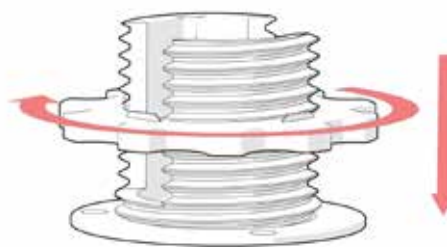

Height adjustable cradle (Code: **79PED45** & **79PED64**).

Components and their use - Fixings



No. 10 Pan head screw (Code: **79SS**) for use with decking clip, starter clip and joist mounting clip.



90° bracket (Code: **79JBK70**) used in corners or joist junctions on 70mm joist.



Stainless steel double clip (Code: **79DC01**), for spacing and retaining the deck boards onto the joists.



90° bracket (Code: **79JBK120**) used in corners or joist junctions on 120mm joist.



Stainless steel starter clip (Code: **79DSC01**), used at the beginning and end of a deck run to retain the edge of the first and last board.



20 / 70mm joist corner brace (Code: **79CB20**), used to create a 90° join between two joists.



Joist mounting clip (Code: **79MP01**), used to mount the 70 and 120mm joists.



No. 8 Pan head screw for use with decking end cap, comes supplied with the decking end cap.



Deck joining plate (Code: **79DJP**), used to join two decking boards.



Black M8 button head machine screw, for use with 90° joist brackets. Supplied in joist bracket kit.



Decking end cap (Code: **79DBEC30A**, **79DBEC30B** & **79DBEC30SS**), used to close off visible end of the decking board.



M8 flanged nut, for use with the 90° joist brackets, supplied in the joist bracket kit.

Understanding your requirements

The installation of the decking system will depend on the exact nature of your site. Consequently, there are some decisions to be made prior to calculating the material requirements.

Base options

Option 1 - Solid base

Laying decking structure over existing firm base, such as existing patio, or concrete slab or flat roof.

Please see page 10

Option 2 - Fresh ground, with no solid base

Decking is being installed over loose ground, soil, etc. The ground has no load bearing capacity and / or is not flat.

Please see page 12

Option 3 - Existing Substructure

An existing structure is in place, and has been judged to be solid and flat enough to provide a solid base for the new decking.

Please see page 13

Option 1 - Solid base

You have an existing base, which is at least as large as the proposed new deck and you are confident that the existing base is strong enough to support the load of the new deck and anything which will go on the deck (including people).

If the existing base is flat and level, you will need to decide on the desired height of the new deck above the existing base (the build-up height). The standard joist heights are 20, 70 and 120mm, to this you need to add the height of the deck board (30mm).

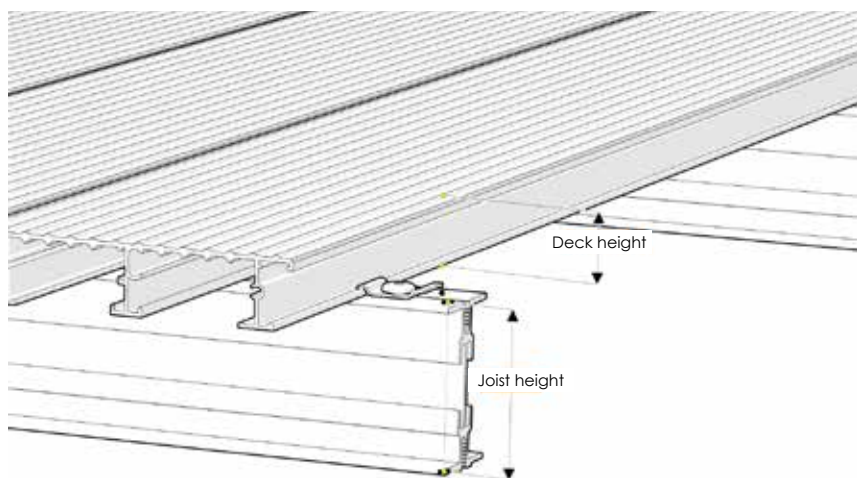

Single joist build-up

This arrangement gives the following height options:

20mm joist + 30mm board = 50mm build-up height.

70mm joist + 30mm board = 100mm build-up height.

120mm joist + 30mm board = 150mm build-up height.

In scenarios where a single joist does not provide sufficient height, it is possible to 'stack' the joist sections to achieve greater build-up.

In a double joist arrangement it is possible to reach 270mm, using a combination of 2 x 120mm base sections and 30mm board.

Once the desired height has been chosen it is possible to calculate the required base section components.

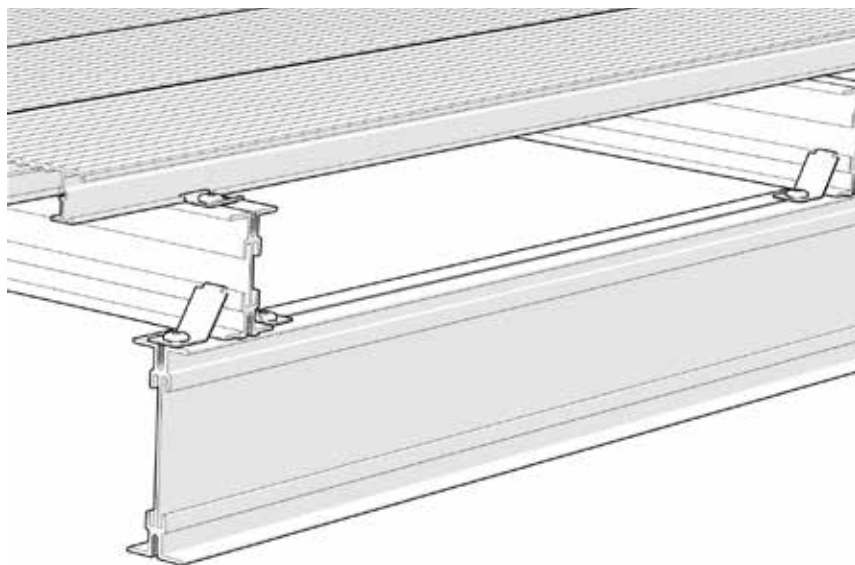

Double joist build-up

Continues on page 11

Option 1 - Solid base (continued)

In instances where the existing base is solid but not level (i.e on a slope or step), It is possible to correct this using the adjustable cradle.

Two cradle options are available:

45mm cradle - 12 - 45mm
(adjustment range 33mm).

64mm cradle - 12 - 64mm
(adjustment range 52mm).

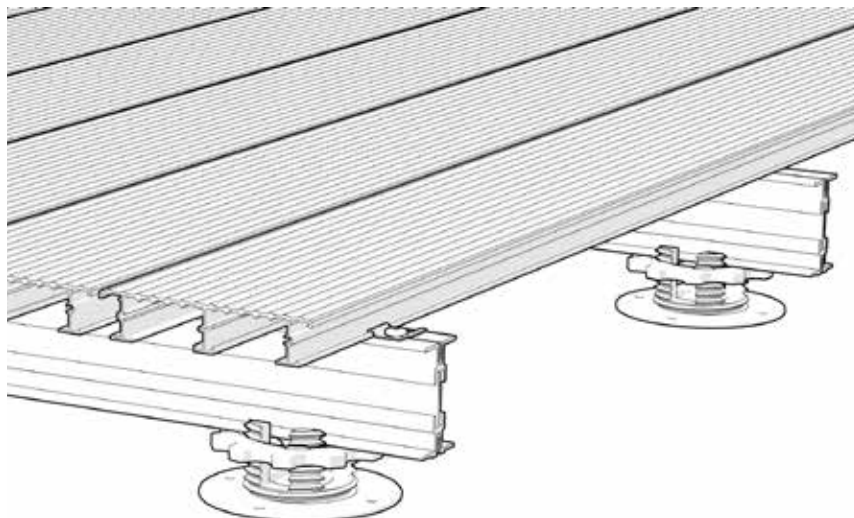

The adjustable cradles operate with a limited range when used in conjunction with the 20mm joist.

Non-mitred base

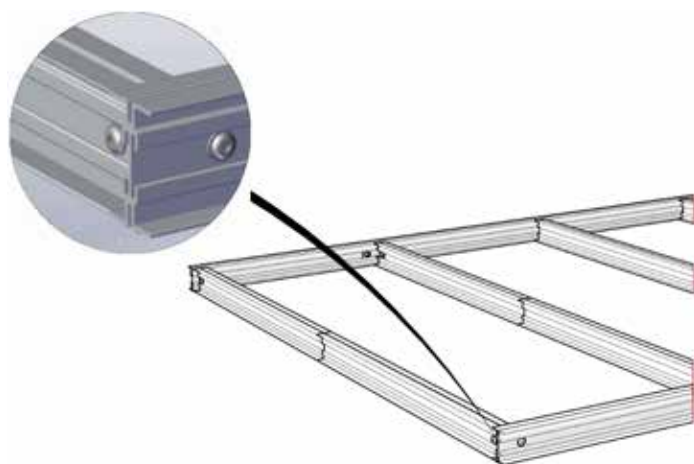

Non-mitred base is easier to create as all the joists are the same length, and there are no mitred cuts on the perimeter section, but it does leave small gaps in the four corners.

Non-mitred base

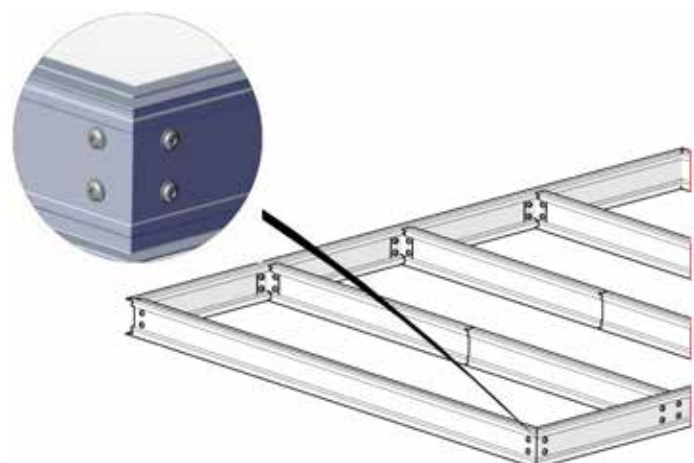

Mitred base is harder to create as all 4 perimeter sections need a mitre cut on either end. Any inaccuracy in the cut angle or the section length will be immediately obvious.

Option 2 - Fresh ground, no solid base

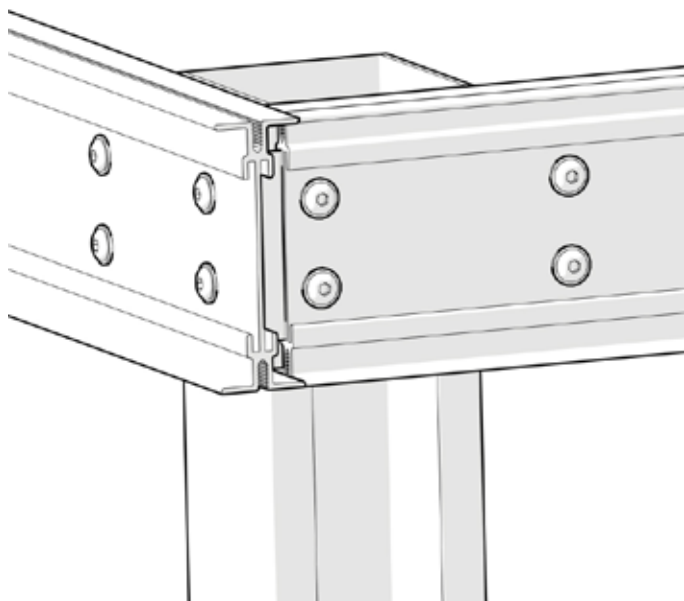

You don't have any existing base in place and instead you are installing your deck over fresh ground. In this instance you will need the decking posts, which will need to be concreted into the ground to a sufficient depth to ensure the base is stable and capable of carrying the load you are planning on, with a suitable safety factor.

The posts will need to be installed at regular intervals, the loading table on the data sheets should be consulted.

It is recommended that the posts are concreted once the frame has been assembled to ensure that everything is straight and level.

Post section should be between 80mm + 100mm with a minimum wall thickness of 3mm if using aluminium or 2mm if using galvanised mild steel.

The post is attached to the deck using the 90° bracket (suitable for the joist being used). The post is not compatible with the 20mm joist.

To fit the bracket, drill the joist and the post using the 8.5mm drill and fix using the Torx bolts and nuts. It is essential that everything is tight before proceeding to the decking stage.

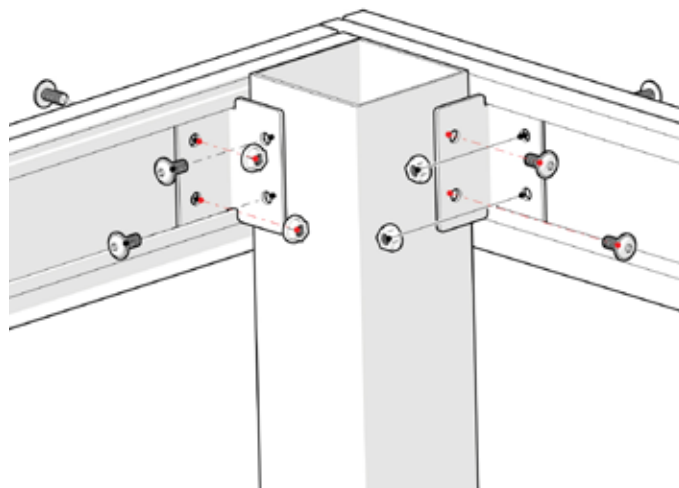

Option 3 - Existing substructure



You have an existing timber base, which is at least as large as the proposed new deck and you are confident that the existing structure is flat, level and is strong enough to support the load of the new deck and anything which will go on the deck (including people).

The 20mm joists can be cut to length using a mitre saw.

If more than one length of the joist is required to cover the desired length, it is not necessary to 'join' the 20mm joists lengthways as the substructure will keep everything in line, so they can simply be butted together.

Screw the 20mm joist profiles onto the top of the existing beams perpendicular to the planned direction of the decking boards. The 20mm joist will need to be drilled to provide a clearance hole for the fixings. It is essential that the heads of the fixings do not stick above the top surface of the joist section.

The ends of the 20mm joists need to be in line.

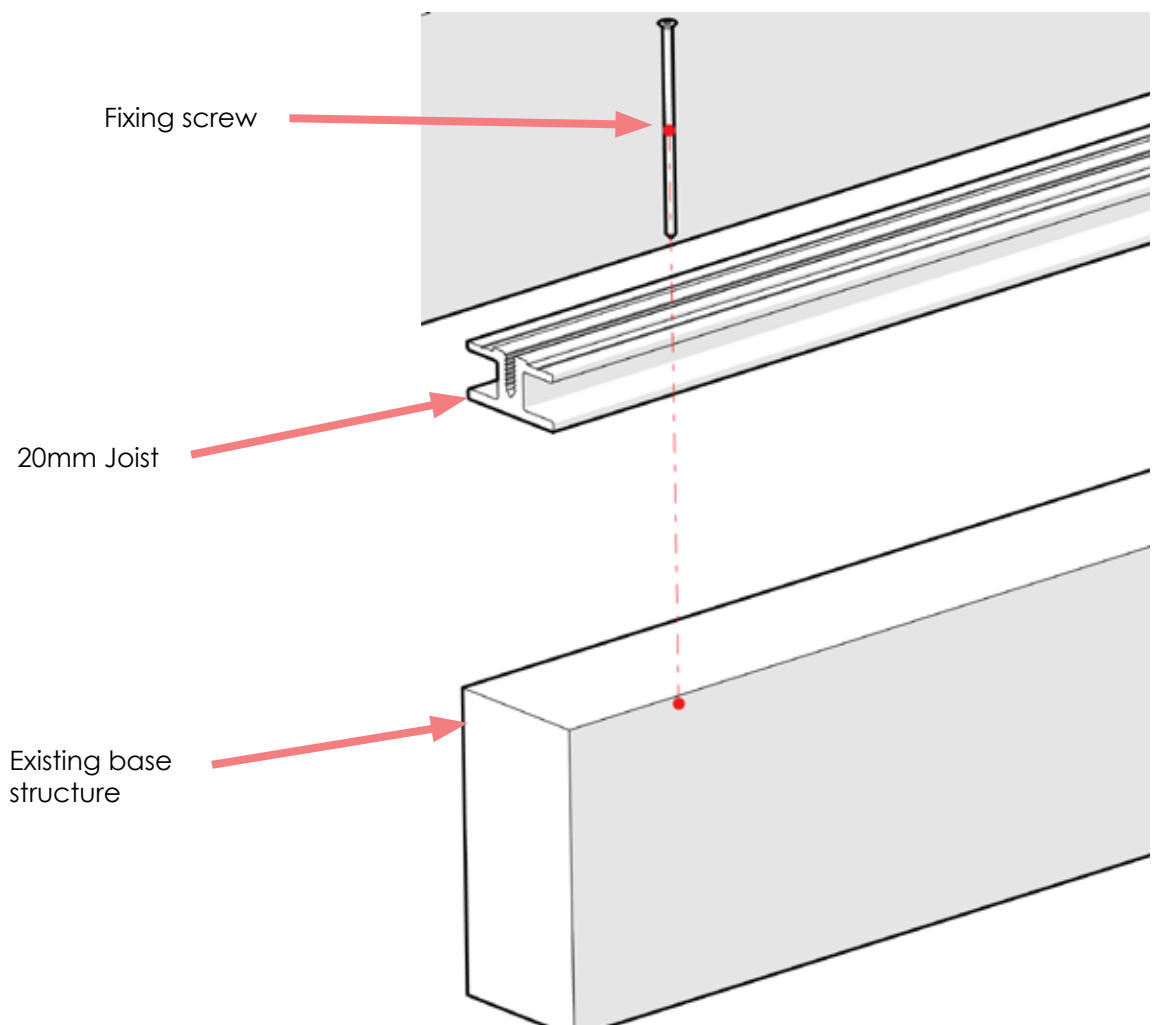

Adjustable cradle installation



The adjustable cradles are designed to make height corrections where the ground is not level.

There are 2 cradle options available, one which covers a range of 12 - 45mm (adjustment range 33mm) and one which covers a range of 12 - 64mm (adjustment range 52mm).

The mounting and operation of the two cradle is identical. Both are fixed to the floor (5mm holes) by either a single fixing in the centre (green arrow) or three fixings around the circumference (red arrows).

Once the cradle is anchored, the nut can be refitted and the joist can then be located into the slot.

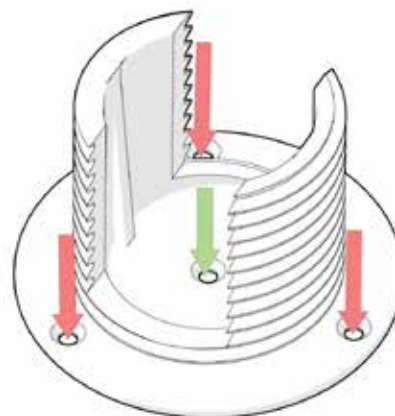

Mounting of cradle
5mm holes

The joist height is then adjusted by turning the nut clockwise to lower the joist and anti-clockwise to raise the joist. Around the perimeter of the nut there are tabs which locate either side of the joist to prevent the nut turning once the joist is in place.

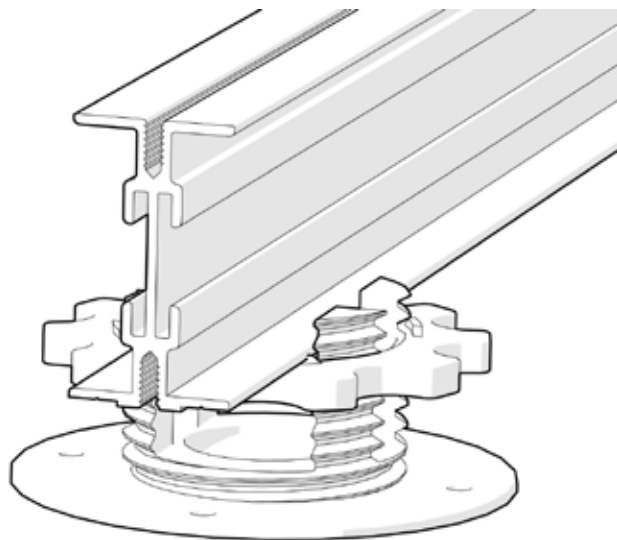

Locating the joist in the cradle

Tabs to prevent rotation

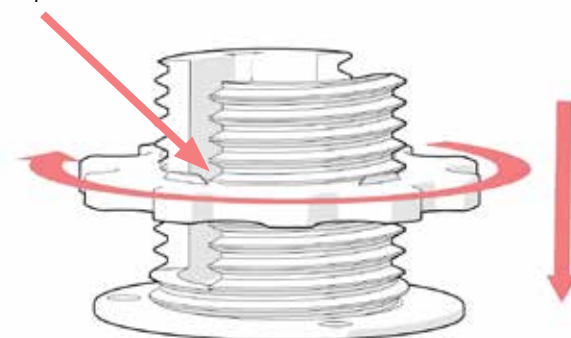

Joist installation

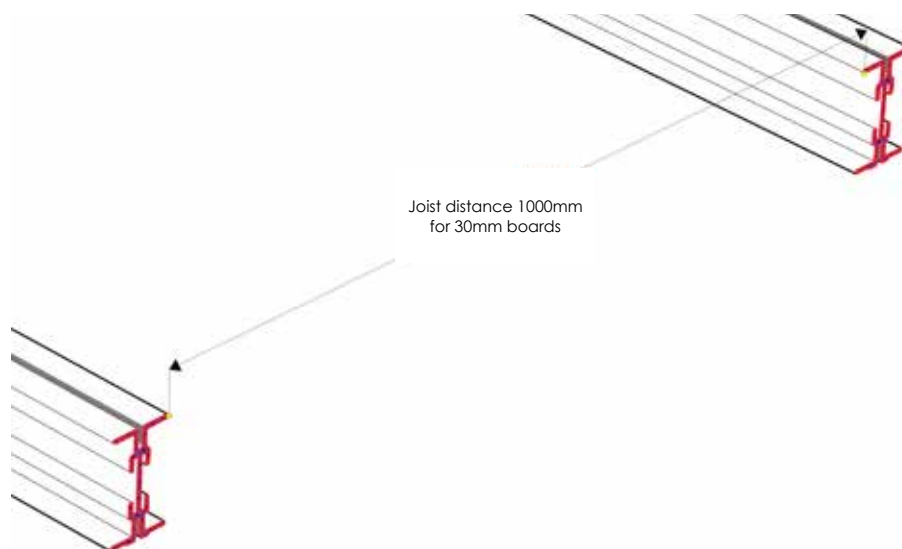

Carefully measure the internal distance from one main joist to the other, where you plan to install the joists (1000mm joist spacing for 30mm boards). If the two main joists are parallel, the joist should all be the same length.

Once you are confident you have the correct dimension, cut the joists to the correct length using the compound mitre saw.

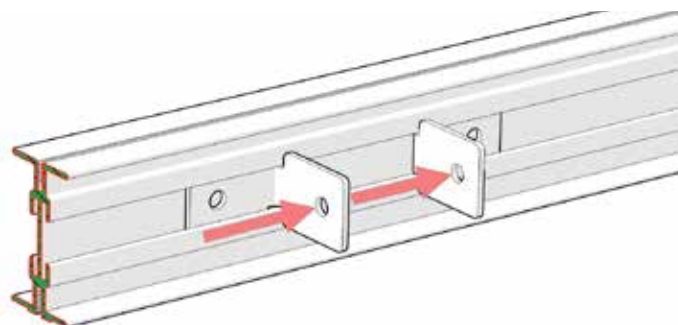

Slide the joist 90° brackets along the main joist, ensure you use 2 brackets per joist and ensure they are handed as pairs (see image).

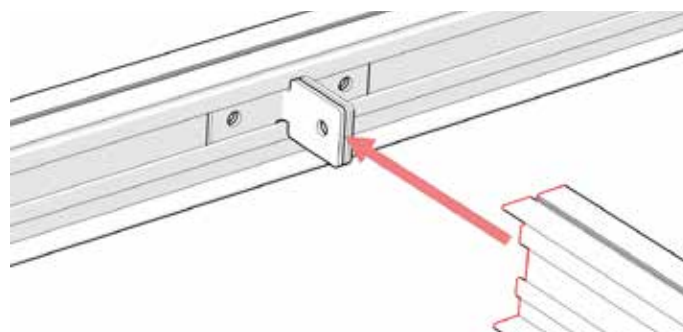

Slide the pre-cut joist onto the 90° brackets. You must install all the joists before starting to bolt them in place.

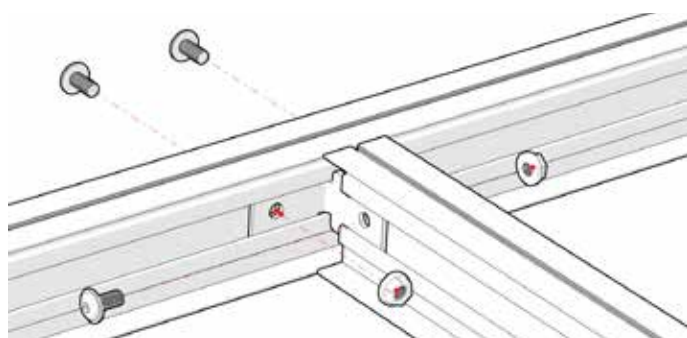

Once the joist is correctly located, clamp the arrangement and drill the joist and main joist, through the holes in the 90° bracket using an 8mm drill bit.

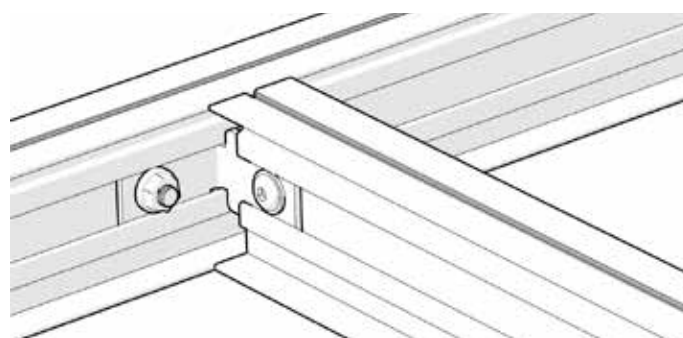

Once drilled, install and tighten the joist fixings. The fixings should be tightened to 16Nm.

Starter clip installation

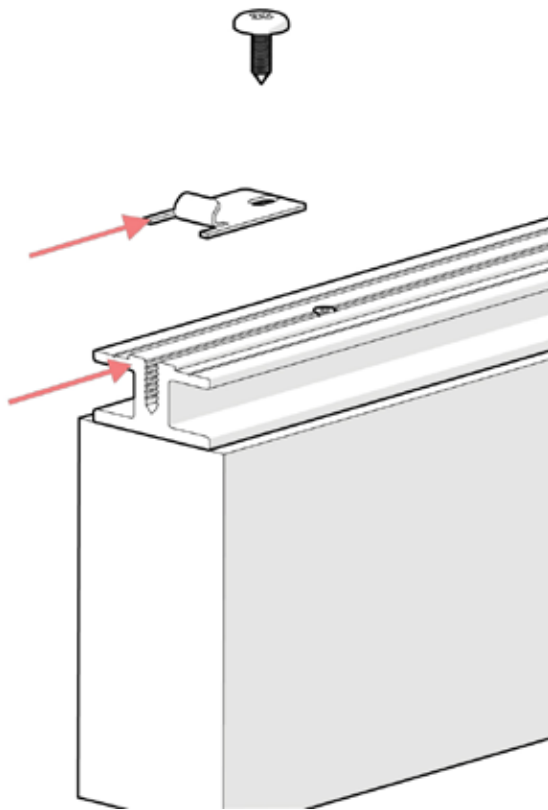

Once the subframe structure is assembled the first job is to install the starter clips. The starter clips create a datum for the rest of the decking installation. It is essential that the starter clips are in line.

The starter clip comes with 2 tabs which act as a guide and should be lined up with the end of the joists. The starter clips are secured with the same fixings as the main clips.

Once the starter clips are installed, the process of installing the boards can begin. The first board hooks under the starter clip and the other side of the board is retained using the standard board clip.

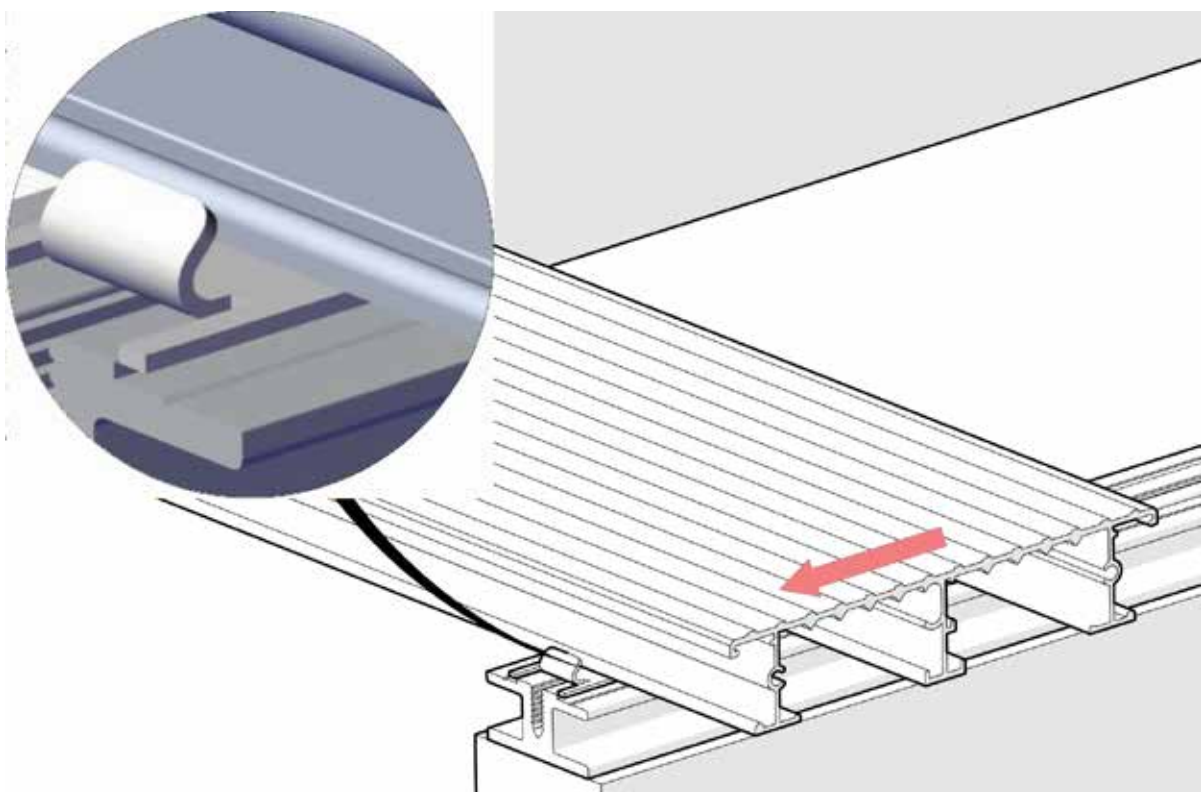

Decking board installation



Step 1

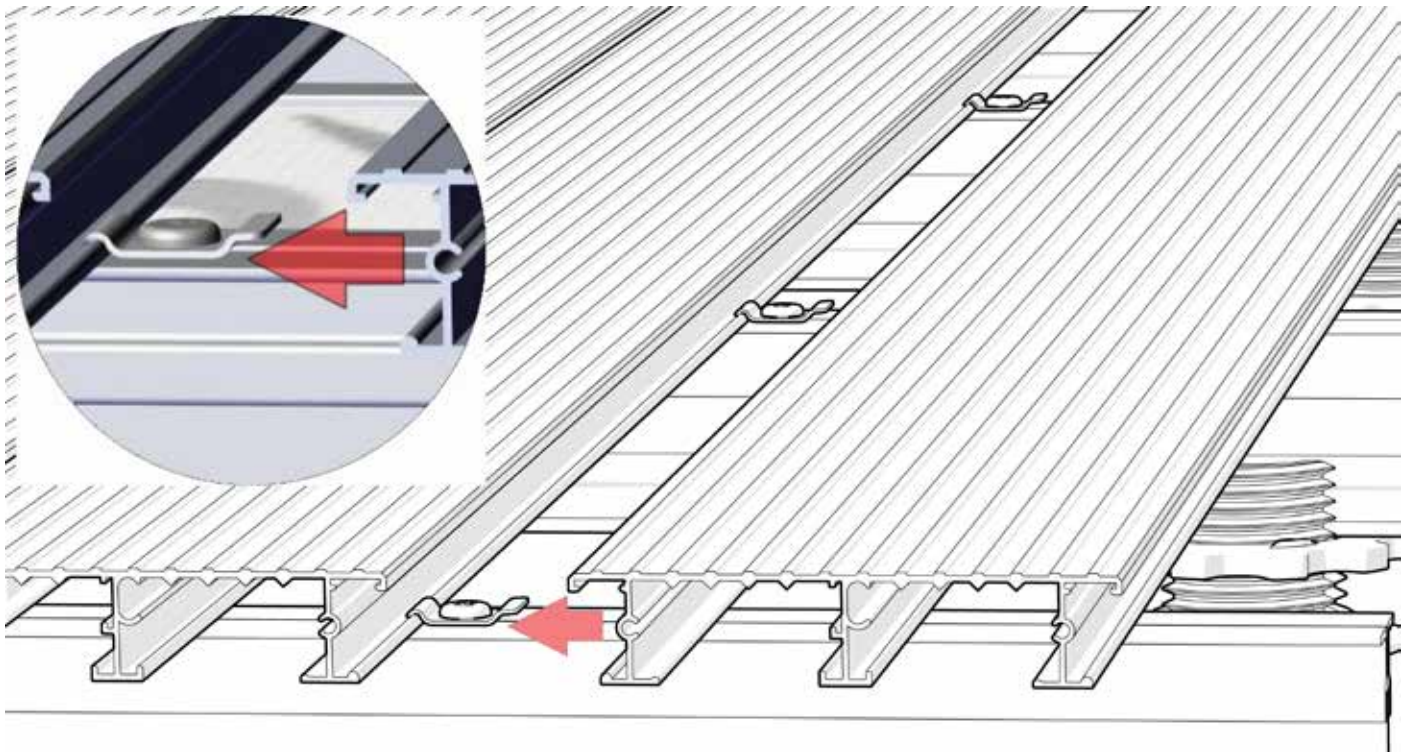

Installing a board is a 2 step process. First the foot of the board is slid under edge of the clip retaining the previous board.

Step 2

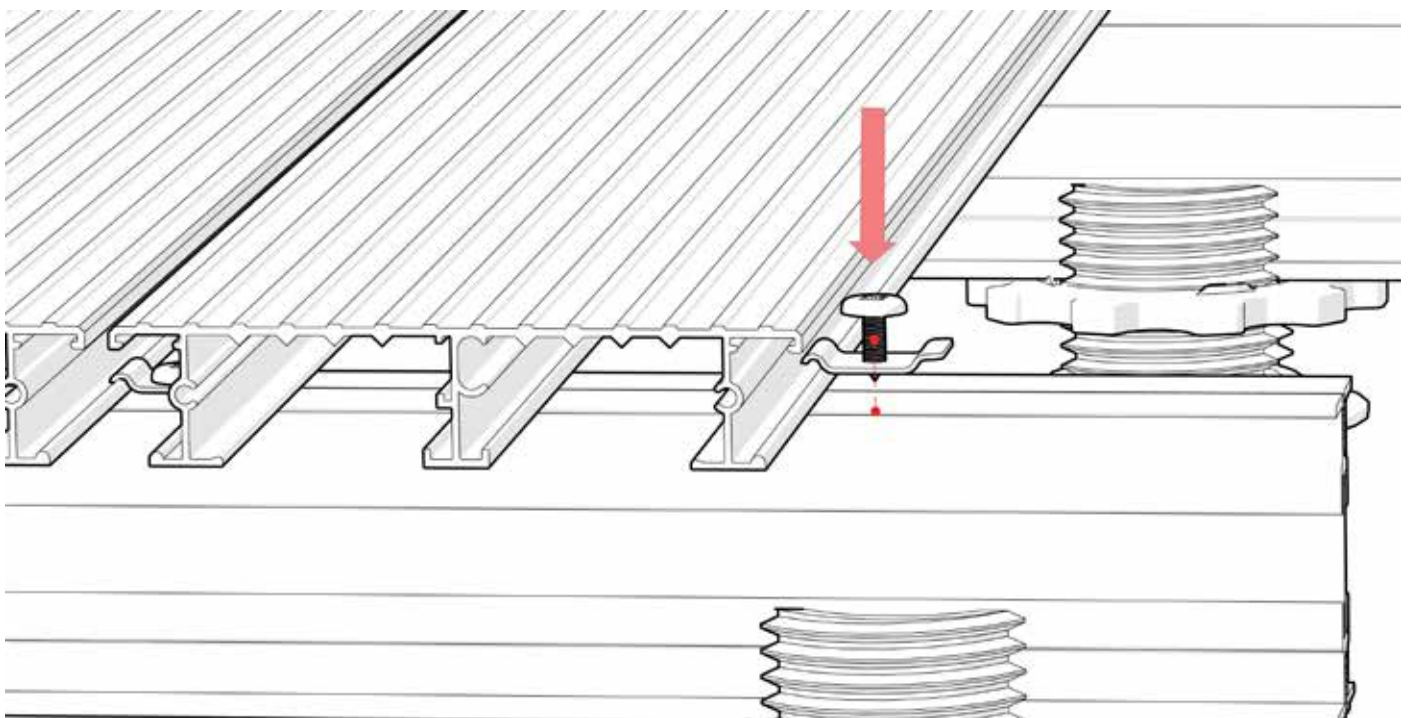

Install the clips on the other side of the board, ensure the clip is orientated with the hook section over the foot of the board, and the flat side left open for the next board to slide under.

Deck joining plate installation

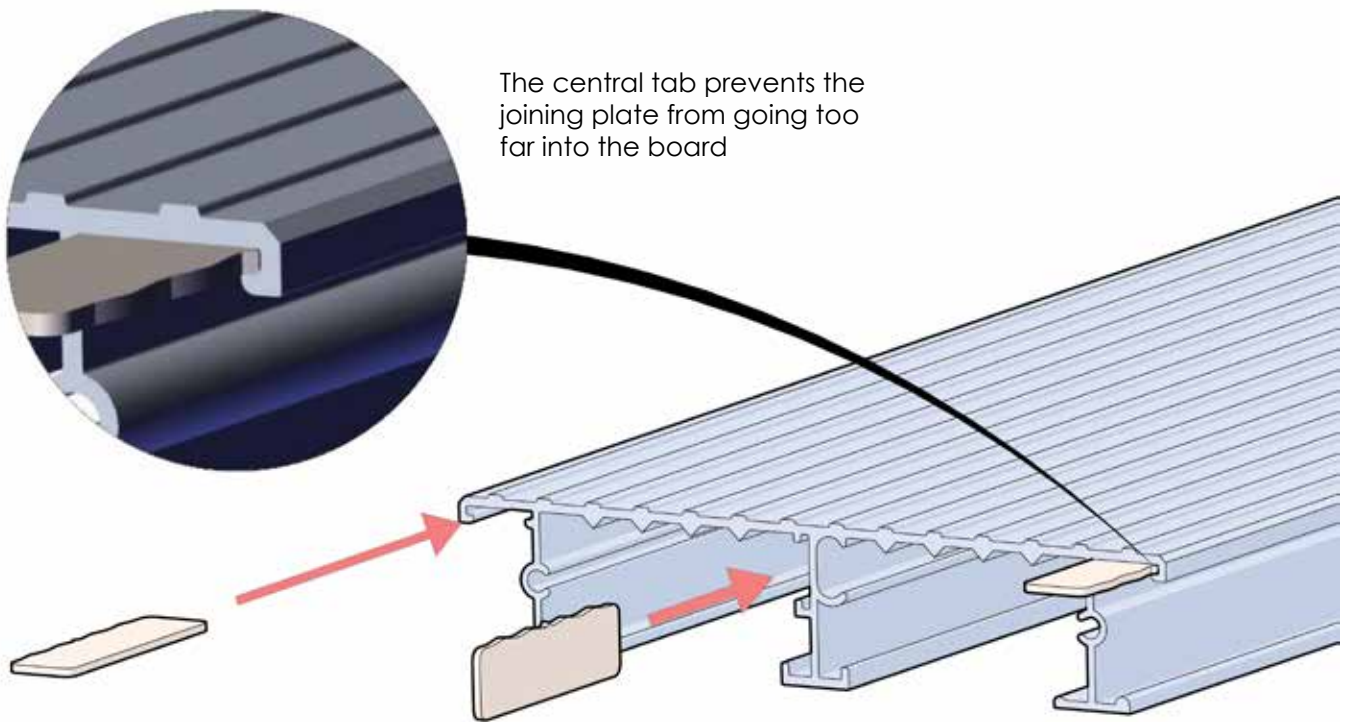

The deck joining plates are used for joining two decking boards together. Three joining plates are required per joint, and should be installed as shown.

The plates are hammered into the end of one of the boards until the central tab on the plate reaches the cut edge of the board.

Once the plates are installed, the other board is located on the other end of the plates and tapped into place using a rubber mallet to avoid damage to the board.

Cutting a board

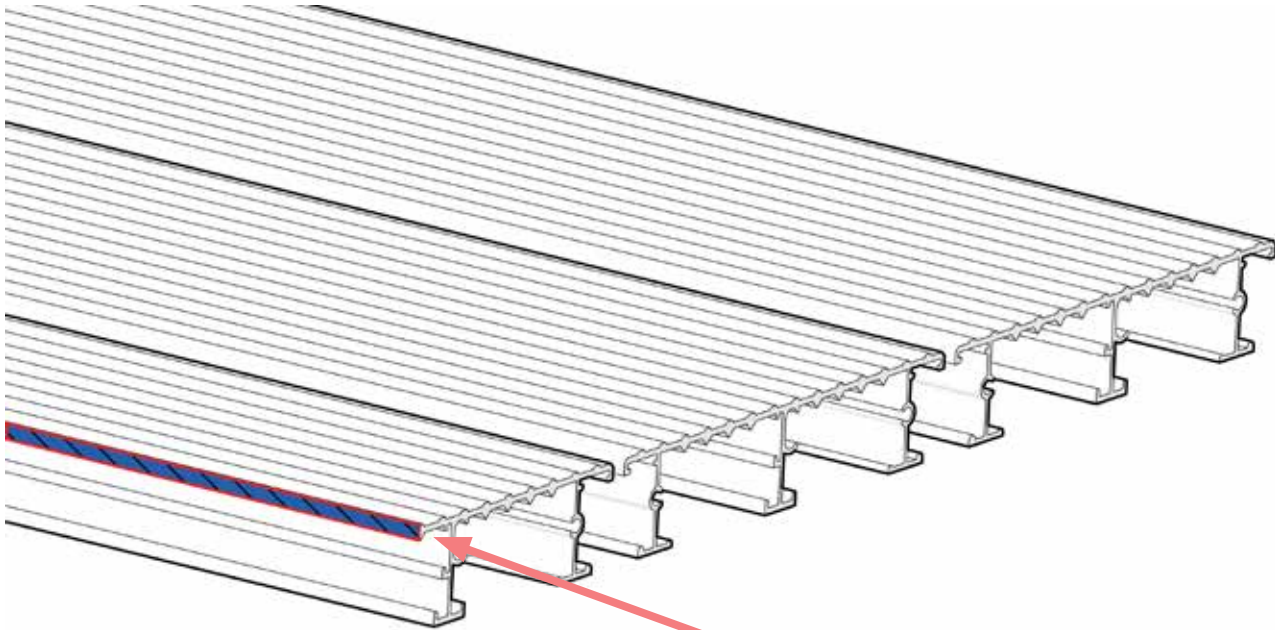

Cutting beyond this point will result in the board only having one leg, which will greatly reduce its stability and is not advised

During installation it is necessary to cut the boards in length. This can easily be done with a compound mitre saw. This should result in a clean cut, which is easily covered using the end cap.

It may also be necessary to reduce the width of the last board within a deck, it is preferable to cut the board which is located against a wall or similar to mask the cut edge. The cut can be carried out using a jigsaw equipped with a metal cutting blade.

It is not recommended to cut beyond the central leg as this will result in a board with just one leg, which is not stable.

Touch up paint for deck boards available

If you should damage your aluminum deck boards during installation, which can happen, they can be touched up to look like new using one of the paints below.

400ml - Anthracite RAL 7016 (Code: **29PC400SASY**)

400ml - Black RAL 9005 (Code: **29PC400SB SY**)

400ml - Serengeti Sand RAL 1019 (Code: **29PC400SSSY**)



Starter clip installation - Final board

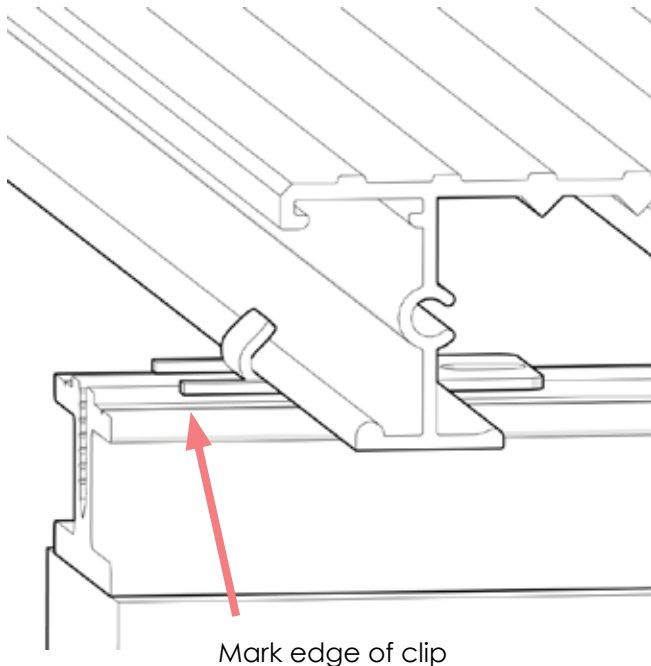

The final board is retained using a starter clip. Once all the boards are secured, the last board is put in place to locate the position of the starter clip. The edge of the clip is then marked to enable correct location of the clip (note this may not always be the end of the joist).

The board is then removed and the clips fitted.

The clips is located using the marking from the previous step. And is secured using the screw.

The screw must be located at the far end of the slot as indicated.

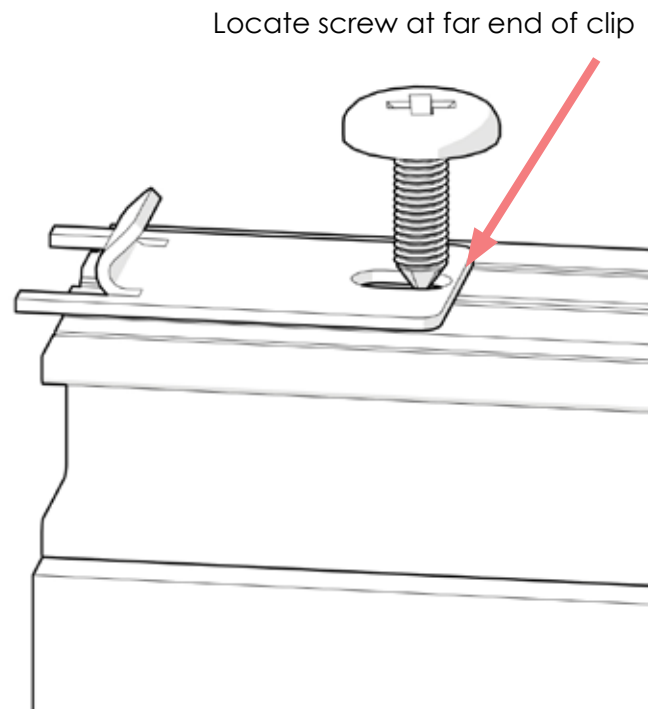
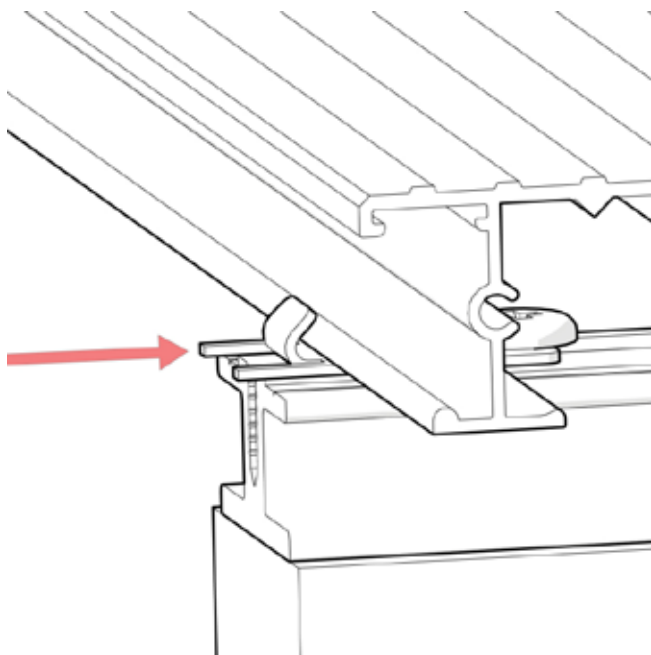

Once the starter clips are installed the last board is refitted and the starter clips are knocked into the final position using a small hammer (take care not to damage the edge of the board). Once the board is hammered into place the board should be tight and fully retained.

End cap installation

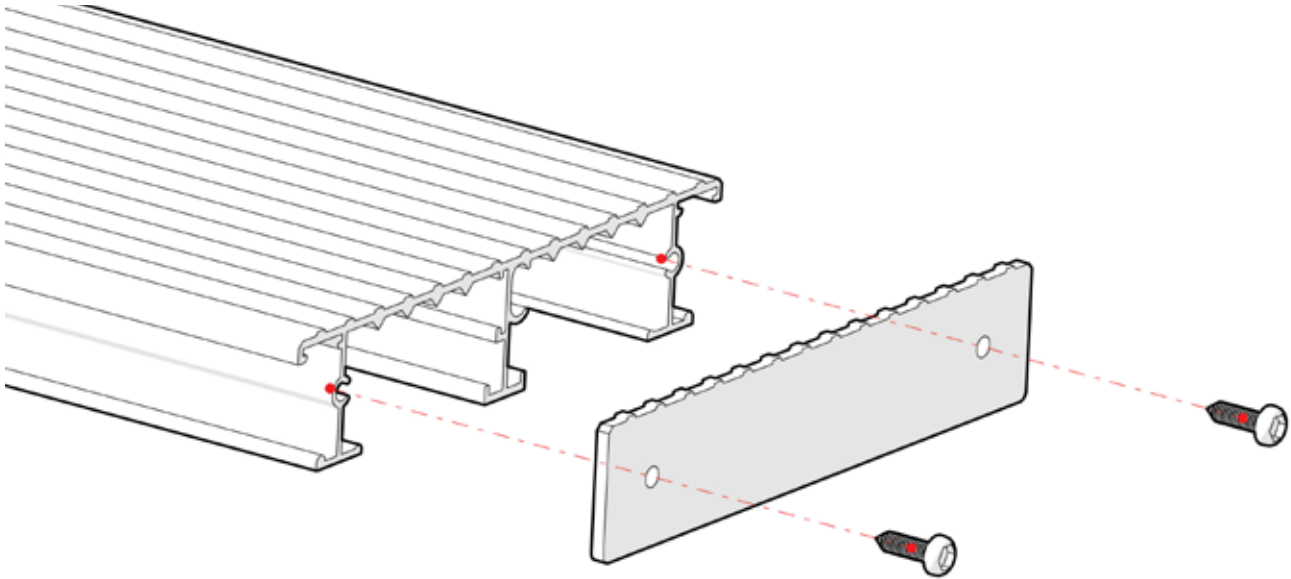

It is essential that the end of the board is cut cleanly and perpendicular to the board to ensure the end cap fits properly. Once the board is cut to length, the end cap can be installed.

The end cap is flat and has the same profile as the board on the upper edge. The cap is secured using 2 x M8 pan head fixings, which are supplied with the end cap. It is also recommended that a small amount of silicon sealant (same colour as the board) is added to the rear of the cap prior to installation to create a more professional finish.



T: 01708 25 35 45 E: sales@brundle.com W: www.fhbrundle.co.uk